

HINO 238

4 x 2 CONVENTIONAL
 GVW 23,000 lbs. BBC 108"
 ENGINE MODEL J08E-TA (Turbo Intercooled)

DIMENSIONS (On standard specification)

Production code		ND8JLSA	ND8JMSA	ND8JP5A	ND8JR5A	ND8JT5A
Wheelbase code		L	M	P	R	T
Wheelbase	A in.	187.0	205.0	217.0	235.0	253.0
Overall length	B in.	302.6	320.6	354.6	372.6	390.6
Overall width	C in.	95.7	95.7	95.7	95.7	95.7
Overall height	D in.	105.9	105.9	105.9	105.9	105.9
Cab to axle	E in.	119.6	137.6	149.6	167.6	185.6
Rear overhang	F in.	75.0	75.0	97.0	97.0	97.0
Frame height at						
Front axle	G in.	36.2	36.2	36.2	36.2	36.2
Rear axle	H in.	39.2	39.2	39.2	39.2	39.2
Road clearance						
(at diff. axle)	J in.	10.6	10.6	10.6	10.6	10.6
Tread						
Front	K in.	78.0	78.0	78.0	78.0	78.0
Rear	L in.	72.0	72.0	72.0	72.0	72.0
Cab Height	in.	69.0	69.0	69.0	69.0	69.0
Turning radius 180°						
Tire	in.	609.4	662.2	697.6	750.4	803.1
Wall to wall	in.	651.2	704.0	739.4	792.1	844.9

CHASSIS WEIGHTS (On std. spec.)

Total weight	MT lb.	9,315	9,405	9,525	9,555	9,625
Front axle	MT lb.	5,940	6,030	6,050	6,105	6,175
Rear axle	MT lb.	3,375	3,375	3,470	3,450	3,450
Total weight	AT lb.	9,235	9,335	9,445	9,490	9,545
Front axle	AT lb.	5,875	5,965	5,985	6,040	6,095
Rear axle	AT lb.	3,360	3,370	3,460	3,450	3,450

POWER LINE & PERFORMANCE 23,000 lbs. GVW

10.00R22.5-14 tires. (Option ratio is combined with 225/70R19.5 tire.)

Power line	Manual		Automatic	
	STD.	OPT.	OPT.	OPT.
Max. speed mph	78	78	78	77
Transmission Model	Eaton F55406A		Allison 2200 RDS	
Type	Six-speed direct drive synchromesh 1st-6th		Five-speed automatic	
Ratios	1st.	9.010	3.102	
	2nd.	5.270	1.811	
	3rd.	3.220	1.406	
	4th.	2.040	1.000	
	5th.	1.360	0.712	
	6th.	1.000	-	
Rev.	8.630	4.492		
Rear axle gear ratios	3.900	3.730	5.290	5.130

ENGINE

Model	HINO J08E-TA - 2004 EPA Certified
Type	Diesel 4-cycle, 6-cylinder in-line, water-cooled
Combustion system	Direct injection type
Max. output (SAE Gross)	220HP at 2,500 rpm
Max. torque (SAE Gross)	520 lb.-ft. at 1,500 rpm
Bore and stroke	4.41 x 5.12 in.
Piston displacement	8 L
Fuel injection	Radial plunger pump (HP-4)
Governor	Electronically controlled
Intake system	Turbocharged and intercooled
Air cleaner	Paper filter type ("DONALDSON")
Fan clutch	Bimetal thermostat sensor, regulates fan speed

HINO  **TRUCKS**™

A TOYOTA Group Company

WWW.HINO.COM [T]248.648 6400

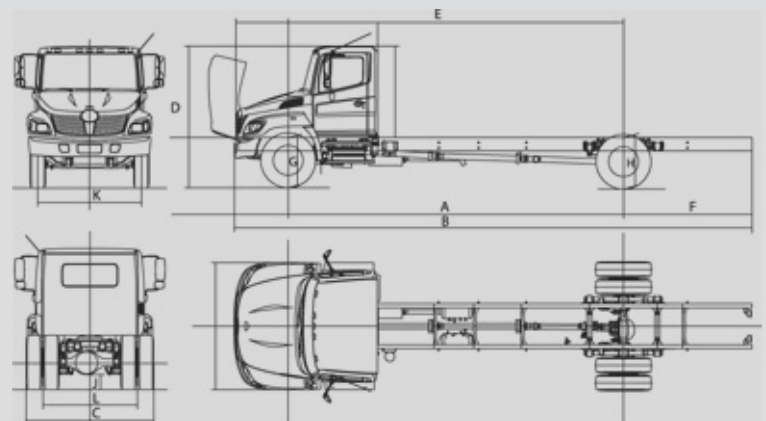

SEE THE 238 IN ACTION AT WWW.HINO.COM

HINO 238

4 x 2 CONVENTIONAL, GVW 23,000 lbs. BBC 108"
ENGINE MODEL J08E-TA (Turbo Intercooled) Spec. No. SS-ND006

WEIGHT CAPACITIES

Front axle	lbs.	8,000
Rear axle	lbs.	17,500
Front spring	lbs.	8,000
Rear spring	lbs.	19,000

LIQUID CAPACITIES

Fuel tank	gal./US	52
Cooling system	gal./US	5.68 : Eaton FS5406A 5.55 : Allison 2200RDS

AXLE / SUSPENSION

Front axle	MFS-8 series reversed Elliot, "I" beam
Front spring	Taper-leaf springs shock absorbers
Rear axle	RS17-145 series full-floating, single reduction single-speed by hypoid gears
Rear spring	Semi-elliptic main and auxiliary helper-leaf spring

FRAME

Ladder type	Straight C channel	
Width	in.	34
Yield strength	PSI	80,000
Resisting bending moment (one side) in_lbs.		1,031,900 no reinforcement

STEERING

Type	Telescopic and tilt steering column TRW-TAS65
------	---

BRAKES

Service brake	Hydraulic system with disc brake for front and rear wheels, with automatic adjustment
Disc diameter x lining width x thickness in.	Front; 15.375 x 18.96 x 0.74 Rear; 15.375 x 18.96 x 0.74
Control	Hydraulic dual circuit with Antilock Brake System(ABS)
Parking brake	Mechanical, internal expanding acting on transmission output shaft
Drum diameter in.	12 : Eaton FS5406A 9 : Allison 2200RDS

WHEELS / TIRES

6 Wheels (Steel)	22.5X8.25 10-stud disc.
6 Tires	10R22.5(G) - Bridgestone R250/M716

CLUTCH

Type	Dry single plate with damper springs EATON-SPICER SAS1401 series
Facing material	Cerametallic
Facing outside diameter in.	13.80
Control	Hydraulic

CHASSIS EQUIPMENT

Fuel pre-filter	Pre-filter (dust) and sedimenter (water)
Reflectors	Two rear, two front side
Hook	One at front

CAB EQUIPMENT

Cab construction	All steel welded
Seating	Three man
Driver's seat	Adjustable, reclining, vinyl covered seat, coil suspension
Passenger's seat	Bench type, vinyl, 2 passenger
Seat belts	3-point type (driver and passenger), one 2-point type (center)
Air conditioner	Denso 134
Heater/Defroster	18,357 BTU/h
Mirrors outside rearview	Four, 1 flat and 1 convex at each side
Sun visors	Two
Windshield	Laminated
Windshield wipers	Dual electric, 2-speed and intermittent
Cruise control	Equipped

DASH INSTRUMENTATION

Meters and gauges ft. lb. system
Speedometer-mph (km/h)
Odometer (mile)
Fuel gauge
Coolant temperature gauge
Engine tachometer
Warning and buzzers
Oil pressure warning lamp and buzzer
Brake pressure warning lamp and buzzer
Coolant level warning lamp and buzzer
Battery charging warning lamp
High beam indicator lamp
Turn signal pilot lamp
Parking brake warning lamp
Engine control system warning lamp
ABS warning lamp

ELECTRICAL EQUIPMENT

Batteries	Two, parallel connection, each 12 V
Capacity	1200 CCA
Alternator	12 V, 100 A, brush (Delco)
Starter	12 V, 4.8 kW
Audio	AM/FM radio with CD player
Headlamps	Integrated with turn signal and hazard lamp

Daytime running lamps
Stop/Tail lamps
Back-up lamps
Side-flasher lamp
Dome lamp
Front side marker lamps
Clearance lamps (front)

Options

<input type="checkbox"/> Cold weather package (Block heater, heated mirror, glow plugs and heated pre-filter/sediment)
<input type="checkbox"/> Cloth seats
<input type="checkbox"/> Single passenger's seat - Adjustable reclining
<input type="checkbox"/> Clutch control with auto adjuster (1401 SOLO)
<input type="checkbox"/> Twin plate clutch (1402)
<input type="checkbox"/> Twin plate clutch control, auto adjuster (1402)
<input type="checkbox"/> Alternator - 12 V, 105 A, brushless (Denso)
<input type="checkbox"/> Dual fuel tank; 52 Gal x 2
<input type="checkbox"/> Fuel tank; 95 Gal
<input type="checkbox"/> Fuel filter; Davco
<input type="checkbox"/> Rear spring; with stabilizer
<input type="checkbox"/> Rear spring; with dual acting shock absorbers
<input type="checkbox"/> Tire size; 255/80R22.5
<input type="checkbox"/> 4 inch extended, front bumper (black)
<input type="checkbox"/> 3 piece, front bumper
<input type="checkbox"/> 4 inch extended, 3 piece, front bumper (black)
<input type="checkbox"/> Power windows
<input type="checkbox"/> Battery GR31
<input type="checkbox"/> Battery GR27 x 3
<input type="checkbox"/> Battery GR31 x 2
<input type="checkbox"/> Engine block heater
<input type="checkbox"/> Heated mirrors

NOTE : All specifications of the products are within normal manufacturing allowances and tolerances. HINO MOTORS SALES U.S.A., INC. reserves the right to alter specifications at any time without previous notice. Some optional items of equipment may require extra time due to the need for their adaptation on the product line.